

HDA | DOUBLE ACTING HIGH TONNAGE CYLINDERS



- ▶ Double acting design offers higher work output with improved performance and efficiency
- ▶ Substantial pulling force in the piston retraction mode provides increased versatility
- ▶ Nitrocarburized cylinder body and piston rod for increased corrosion protection
- ▶ Low friction bearing surfaces
- ▶ Internal annular area overload protection valve
- ▶ Anti-extrusion seals for improved performance at high pressures
- ▶ Flat saddle, collar thread and piston rod thread as standard on all models up to 224 tons
- ▶ Replaceable tilting saddle fitted as standard on models from 359 tons and upwards
- ▶ Lifting ring as standard on models from 55 to 120 tons
- ▶ Eyebolts as standard on models from 168 to 1115 tons
- ▶ Optional piston rod saddles listed on pages 24 and 25

Capacities from 28 to 1115 tons

Stroke lengths from 5.99 to 20.02 inches

Working pressure 10000 psi

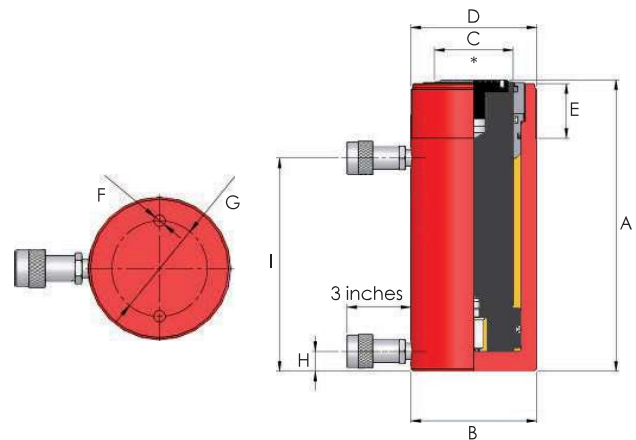

Note: Base mounting holes (F) will not withstand full load. Base mounting holes for easy positioning. Base mounting holes on model HDA5020 are at a random angular orientation to the cylinder ports.

**see pages 24 and 25*

Model number	Capacity (tons)		Stroke (in)	Oil capacity (in ³)	Cylinder eff. area (in ²)	Weight (lbs)
	Push	Pull				
HDA256	28	11	5.99	32.34	5.41	33.1
HDA506	55	17	5.99	65.91	11.05	62.6
HDA5013	55	17	13	143.41	11.05	93.9
HDA5020	55	17	20.02	220.91	11.05	138.4
HDA1006	120	40	5.99	142.19	23.76	142.2
HDA10013	120	40	13	308.78	23.76	196.2
HDA1506	168	87	5.99	198.94	33.2	198.4
HDA15012	168	87	12.02	398.48	33.2	265.7
HDA2006	224	104	5.99	264.23	44.21	286.2
HDA20012	224	104	12.02	530.3	44.21	369.1
HDA3006	359	-	5.99	424.11	70.9	425.5
HDA4006	439	-	5.99	518.09	86.63	630.5
HDA5006	573	-	5.99	676.75	113.13	820.1
HDA8006	892	-	5.99	1054.49	175.79	1433.0
HDA10006	1115	-	5.99	1319.33	220.00	1984.1

Dimensions (in) <i>(unless otherwise stated)</i>									
A	B	C	D	E	F	G	H	I	J
11.31	3.62	1.97	3 5/16"-12 UN	2.09	M10	2.36	1.18	8.35	40°
11.62	5	3.11	5"-12 UN	2.17	M12	3.35	0.79	8.51	30°
18.64	5	3.11	5"-12 UN	2.17	M12	3.35	0.79	15.52	30°
28.76	5	3.11	5"-12 UN	2.17	M12	3.35	2.68	25.06	30°
11.98	7.29	4.49	6 7/8"-12 UN	2.01	M12	5.75	1.18	8.9	30°
18.99	7.29	4.49	6 7/8"-12 UN	2.01	M12	5.75	1.18	15.92	30°
12.21	8.27	4.49	8"-12 UN	2.17	M16	6.3	1.38	9.1	30°
18.24	8.27	4.49	8"-12 UN	2.17	M16	6.3	1.38	15.13	30°
12.88	10.01	5.52	9 3/4"-12 UN	2.56	M20	7.29	1.69	9.38	30°
18.91	10.01	5.52	9 3/4"-12 UN	2.56	M20	7.29	1.69	15.41	30°
16.11	12.29	6.5	Optional	Optional	M20	6.23	1.97	10.32	30°
16.98	14.18	8.51	Optional	Optional	M24	8	2.17	10.91	30°
18.52	15.64	8	Optional	Optional	M24	8	2.56	11.82	30°
21.08	19.70	11.82	Optional	Optional	Optional	Optional	2.76	12.53	30°
23.25	21.28	12.61	Optional	Optional	Optional	Optional	3.90	14.07	30°

Note: Other capacities and stroke lengths available on request.

If specifying this cylinder for use with the SLF and SLV synchronous lifting systems and associated mounting kit, please consider the increase in dimension A (closed height), see pages 43 and 47.