

TL | TOUGHLIFT JACKING SYSTEMS



- ▶ Choice of air or electric driven hydraulic system
- ▶ High flow 3-stage pump unit offers faster advance and retract times
- ▶ Solid tyres fitted as standard with option of pneumatic tyres
- ▶ Narrow width wheels and redesigned wheel position for better ground clearance and balance when maneuvering
- ▶ Push button remote hand pendant controller with 16.5 feet control cable
- ▶ Tilting saddles fitted as standard on all models
- ▶ User friendly design with easily accessible maintenance features
- ▶ Wide range of accessories available for even greater versatility see pages 77 and 78

Choice of 8 models with capacities from 55 to 220 tons

Lifting heights up to 27 inches

Working pressure 10000 psi

Dimensions for 55 ton models:

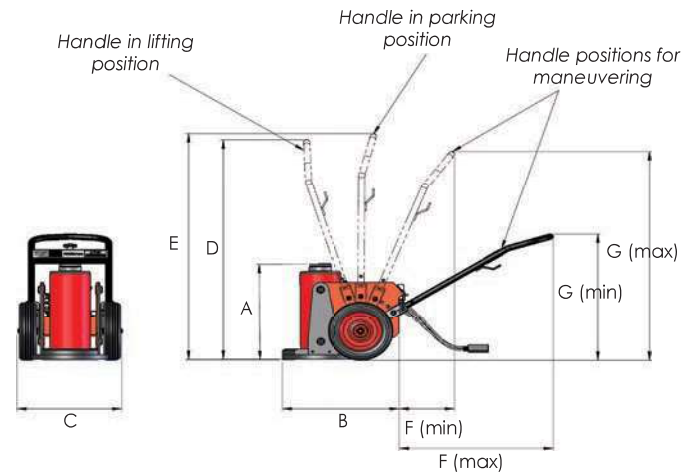

Dimensions for all other models:

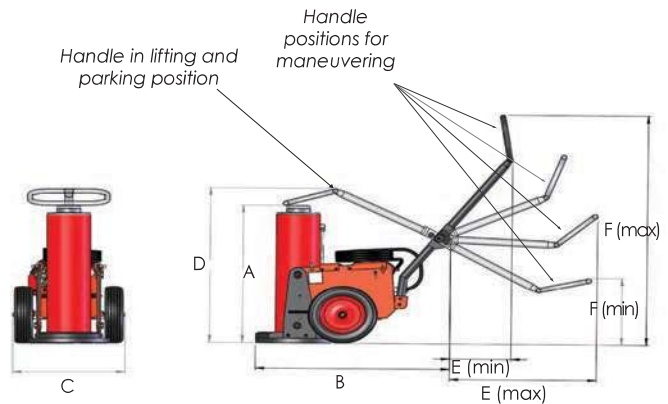

Model number	Capacity (tons)	Power supply	Stroke (in)	Weight (lbs)	Max additional stack (in)	Dimensions (in)						
						A	B	C	D	E (min-max)	F (min-max)	G (min-max)
TL050A255	55	90-psi air driven	10.01	352.7	26.79	17.93	26	22.06	56.74	56.74	14.97-39.4	27.58-51.22
TL050E255	55	240V electric, 50 Hz	10.01	370.4	26.79	17.93	26	22.06	56.74	56.74	14.97-39.4	27.58-51.22
TL050E255H	55	240V electric, 60 Hz	10.01	370.4	26.79	17.93	26	22.06	56.74	56.74	14.97-39.4	27.58-51.22
TLA10016	110	90-psi air driven	15.96	637.1	18.91	26.2	44.52	25.69	32.74	14.03-33.65	18.32-63.24	-
TLA10021	110	90-psi air driven	20.88	703.3	7.09	33.21	44.52	25.69	37.27	14.03-33.65	18.32-63.24	-
TLA15015	165	90-psi air driven	15.37	690.0	19.11	26.2	44.52	25.69	32.9	14.03-33.65	18.32-63.24	-
TLA15020	165	90-psi air driven	20.49	769.4	7.09	33.21	44.52	25.69	37.94	14.03-33.65	18.32-63.24	-
TLA20015	220	90-psi air driven	15.01	822.3	19.7	26	44.52	25.69	32.7	14.03-33.65	18.32-63.24	-
TLA20027	220	90-psi air driven	27	998.7	7.09	37.98	44.52	25.69	42.75	14.03-33.65	18.32-63.24	-

Note: 110, 165 and 220 ton electric driven Hi-Force ToughLift jacking systems available on request